

PATTERSON

AUTOMATIC SYSTEM FEEDER PACKAGES



Type "GMP"

Water/Glycol Solution And
Water Solution Make-up Packages

GMP Systems

The Patterson GMP Glycol/Water Make-Up Package is a complete fully automated and autonomous system. Its function is to automatically supply pressurized water, or water-glycol mixture to a closed-loop space heating, chilled water, snowmelt, radiant heating, or process control system, to insure that critical minimum system pressure levels are maintained. The basic GMP consists of a solution reservoir and a pump pressurization control station. The pre-mixed fluid stored in the reservoir is manually maintained and isolated from the buildings plumbing, ensuring that there is no potential for cross-contamination into the buildings potable supply. The pump pressurization control station stores a portion of the fluid under pressure, and meters it to the heating or process control system at the precise pressures required.

A low fluid level sensor is utilized to shut-down the pump operation and sounds an alarm to the operator to investigate the GMP.

PATTERSON
AUTOMATIC SYSTEM FEEDER PACKAGES

GMP Features

FULLY AUTOMATIC FILL PACKAGE

Maintains water/glycol solution or water solution levels in closed loop heating and cooling systems at optimum design pressures. Pressure adjustable. Pump operates to re-pressurize solution contained in the Pressurization Control Station.

PRE-WIRED, PRE-PIPED PACKAGE

Tank, pump and all controls packaged for easy connection to closed loop systems requiring filling, mixing and storage of make-up solutions.

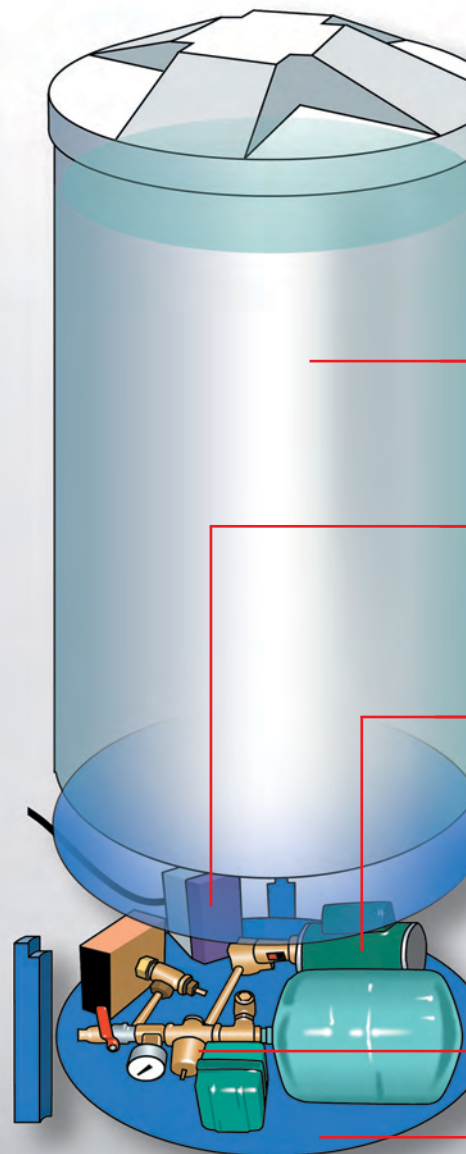

PREVENTS MAJOR FLOODS.

In the event of a system rupture, only the contents of the storage tank will be pumped into the system.

NO DIRECT CONNECTION TO POTABLE WATER SUPPLY.

Eliminates the need for backflow prevention devices

PROVIDES LEAK DETECTION.

Dropping solution level in storage tank warns of developing system leak.

FREEZE LEVEL PROTECTION.

Maintains predetermined glycol/water solution mixture to closed loop systems.

TREATMENT CHEMICALS.

Allows mixing of treatment chemicals in make-up water, if desired.

EPA PROTECTION AND EXCESSIVE PRESSURE CONTROL

Piping relief valve to the solution reservoir eliminates EPA concerns of solution disposal.

Solution Reservoir

- Visible solution level with scale
- Hypoallergenic
- Easy access for re-filling

Low Fluid Alarm

- Safety shut-off shuts system down if solution level gets low.
- Notifies operator with audible and visual alarms.

Pressurization Control Station

- Excessive pressure protected by cut-off switch
- Low liquid level audible alarm (can be silenced)
- Low liquid level visible alarm
- Pump protection alarm

Pressure Regulating Valve

- Maintains optimum system design pressure

Sturdy Base

- Steel construction
- Easy access to components

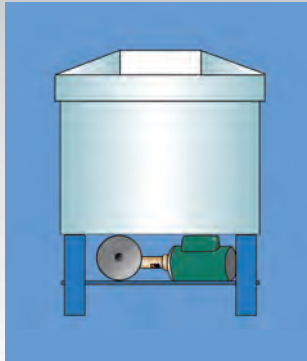

Single System GMP Units

The single system GMP is designed to automatically service one closed-loop space heating, chilled water, snowmelt, radiant heating, sprinkler, or process control system. This GMP-series is available with 50 or 100-gallon reservoir capacities and $\frac{1}{8}$ or $\frac{1}{2}$ -HP pump pressurization control station with magnetic starter. The $\frac{1}{8}$ -HP station is used for systems requiring up to 50-PSI metering pressure, and the $\frac{1}{2}$ -HP station is used for systems up to 70-PSI.

Models

GMP-13050: $\frac{1}{8}$ -HP Pump with 50-gallon reservoir
GMP-13100: $\frac{1}{8}$ -HP Pump with 100- gallon reservoir
GMP-15050: $\frac{1}{2}$ -HP Pump with 50-gallon reservoir
GMP-15100: $\frac{1}{2}$ -HP Pump with 100-gallon reservoir

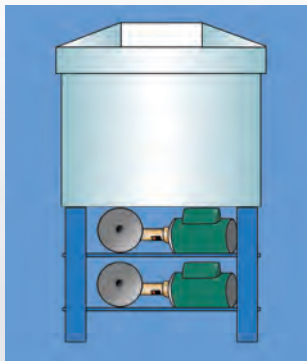

Duplex GMP Units

The Duplex GMPD is designed to automatically service two separate closed-loop space heating, chilled water, snowmelt, radiant heating, sprinkler, or process control systems. This GMPD-series is available with 50 or 100-gallon reservoir capacities and with two (2) $\frac{1}{8}$ or (2) $\frac{1}{2}$ -HP pump pressurization control stations with two (2) magnetic starters. The $\frac{1}{8}$ -HP stations are used for systems requiring up to 50-PSI metering pressure, and the $\frac{1}{2}$ -HP stations is used for systems up to 70-PSI.

Models

GMPD-23050: (2) $\frac{1}{8}$ -HP Pumps with (1) 50-gallon reservoir
GMPD-23100: (2) $\frac{1}{8}$ -HP Pumps with (1) 100- gallon reservoir
GMPD-25050: (2) $\frac{1}{2}$ -HP Pumps with (1) 50-gallon reservoir
GMPD-25100: (2) $\frac{1}{2}$ -HP Pumps with (1) 100-gallon reservoir

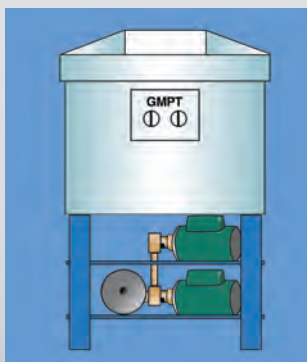

Twin GMP Units

The Twin GMPT is designed to automatically service one closed-loop space heating, chilled water, radiant heating, sprinkler, or process control system. This GMPT-series is available with 50 or 100-gallon reservoir capacities and with (1) pump pressurization control station with (2) $\frac{1}{8}$ or (2) $\frac{1}{2}$ -HP pumps. A control panel with alternator and two magnetic starters is used to alternate between the two (2) pumps. The $\frac{1}{8}$ HP station is used for systems requiring up to 50-PSI metering pressure, and the $\frac{1}{2}$ -HP station is used for systems up to 70-PSI.

Models

GMPT-33050: (2) Alternating $\frac{1}{8}$ -HP Pumps with (1) 50-gallon reservoir
GMPT-33100: (2) Alternating $\frac{1}{8}$ -HP Pumps with (1) 100- gallon reservoir
GMPT-35050: (2) Alternating $\frac{1}{2}$ -HP Pumps with (1) 50-gallon reservoir
GMPT-35100: (2) Alternating $\frac{1}{2}$ -HP Pumps with (1) 100-gallon reservoir

Dimensional Data

Model Number	Make-up Capacity (gpm @ psi)	Pump HP	Tank Volume (gal.)	Pressure Range (psi)	Dimensions		Approx. Weight (lbs.)
					Height (in.)	Width (in.)	
GMP Glycol/Water Make-up System							
GMP-13050	1.8@50	1/3	50	10-50	42	28	100
GMP-13100	1.8@50	1/3	100	10-50	66	28	116
GMP-15050	1.7@70	1/2	50	10-70	42	28	103
GMP-15100	1.7@70	1/2	100	10-70	66	28	119
Duplex GMP Glycol/Water Make-up System							
GMPD-23050	1.8@50	1/3	50	10-50	52	28	200
GMPD-23100	1.8@50	1/3	100	10-50	76	28	220
GMPD-25050	1.7@70	1/2	50	10-70	52	28	206
GMPD25100	1.7@70	1/2	100	10-70	76	28	229
Twin GMP Glycol/Water Make-up System							
GMPT-33050	1.8@50	1/3	50	10-50	52	38	210
GMPT-33100	1.8@50	1/3	100	10-50	76	38	230
GMPT-35050	1.7@70	1/2	50	10-70	52	38	216
GMPT-35100	1.7@70	1/2	100	10-70	76	38	233

Typical Specification

- The contractor shall supply and install, as indicated on the plans and in the specifications, a prefabricated, automatic and autonomous make-up package for (the) (each) glycol system.
- The package shall be designed to occupy a minimum amount floor space to operate on a standard 110V, 60 Hz electrical circuit, and to maintain a fill pressure in the glycol system of _____ psi. The pumping assembly shall be mounted in a sturdy steel frame with legs to keep it off the floor.
- It shall include a _____ (US GPM) at _____ (psi) pump, a (1/3) or (1/2) HP motor, a magnetic starter, a pressure tank with pressure control, a priming valve, a pressure reducing valve, a shut-off valve and a pressure gauge. It shall be connected to the system with a 1/2" NTP connection. It shall feature a cut-off and alarm arrangement, which will stop the pump in case of excessive pressure, or a low solution level, and activate an audible (which can be silenced) and a visual alarm. An 110V dry contact shall also be available for a remote alarm.
- A translucent polyethylene (50) or (100) gallon solution reservoir, complete with lid, shall be mounted on the pumping assembly and shall include a strainer and a shut off valve. A _____ in. NTP glycol solution recovery line shall be piped in from the system relief valve out let to the solution container, through its lid in such away that the lid can be removed for filling and mixing.
- The make-up package shall be Patterson model GMP- _____ with discharge pressure factory preset at 12 psi, and field adjustable as sold by _____.

For Duplex GMP Systems replace paragraph 3 with:

- The system shall consist of two independent pressurization modules for two glycol/water applications. Each module shall include a _____ (US GPM) at _____ (psi) pump, a (1/3) or (1/2) HP motor, a magnetic starter, a pressure tank with pressure control, a priming valve, a pressure reducing valve, a shut-off valve and a pressure gauge. It shall be connected to the system with a 1/2" NTP connection. It shall feature a cut-off and alarm arrangement, which will stop the pump in case of excessive pressure, or a low solution level, and activate an audible (which can be silenced) and a visual alarm. An 110V dry contact shall also be available for a remote alarm.

For Twin GMP Systems replace paragraph 3 with:

- It shall include two _____ (US GPM) at _____ (psi) pump, a (1/3) or (1/2) HP motor, magnetic starters, a pressure tank with pressure control, a priming valve, a pressure reducing valve, a shut-off valve and a pressure gauge. It shall be connected to the system with a 1/2" NTP connection. It shall feature a control panel equipped with H-O-A switches for each pump starter, and a fail safe alternator that allows one pump to operate if the other pump malfunctions. It shall feature a cut-off and alarm arrangement, which will stop the pump in case of excessive pressure, or a low solution level, and activate an audible (which can be silenced) and a visual alarm. An 110V dry contact shall also be available for a remote alarm.

